

MAGNETIC DRIVEN GEAR PUMPS Series TEF-MAG

TEF-MAG 3500

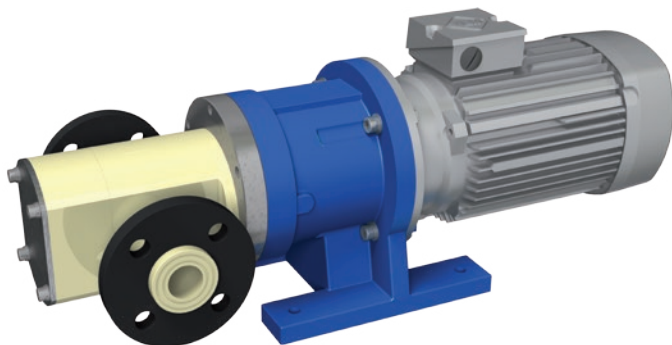

TECHNICAL DATA

Nominal speed:	1450 1/min (50Hz) 1750 1/min (60Hz)
Nominal flow:	3650 l/h (965 us gph) 4650 l/h (1228 us gph)
Discharge pressure, max.:	10 bar (145 psi)
Design pressure:	PN 16 bar (232 psi)
Temperature, max.:	65°C (149°F)
Density, max.:	1,9 kg/dm ³
Viscosity, max.:	10000 cP

APPLICATIONS

The pumps have proven their performance in every application that requires lower flow rates and high discharge pressures in combination with corrosive liquids and pulsation-free supplies.

Typical Applications:

- Biodiesel Plants
- Waste Water Treatment
- Environment Engineering
- Metering Applications
- Plant Engineering
- Equipment Engineering
- Pharmaceutical-, Medical-, Bio- Engineering

CONNECTIONS

Threaded:	G1 1/4" female
Flanged:	DN32 PN10/16 ANSI 1 1/4"

MATERIALS

Housings: PP, PVDF, PTFE
O-Rings: EPDM, Viton, Kalrez
Shafts: Al₂O₃ >99%, SSiC
Gears: PTFEC
Bearings: PTFEC, Kohlegraphit

FEATURES AND BENEFITS

- No need in expensive high alloys like Duplex or Hastelloy
- Rotary positive displacement pump
- External gear pump
- Nearby pulsation free
- Leak-free
- Magnetic driven
- Low NPSHR-value of 0,6m only
- Leak-free
- Rugged
- Corrosion-resistant
- Self-priming
- Dry-run capable
- Small and compact design
- Linear performance curves while variable speed controlling
- High discharge pressures
- Low flow rates
- Integrated Variable Frequency Drive (available on request)
- Pump acc. to ATEX 2014/34/EU

PRODUCT DESCRIPTION

MARCH Series TEF-MAG gear pumps are corrosion resistant, non-metallic, rotating positive displacement pumps, external gear type and magnetically coupled. TEF-MAG gear pumps generate low flows with high discharge pressures and approximately no pulsation. The pump housing is made of resistant solid block plastics like PP, PVDF or PTFE. The internal hydraulic parts like gears and shafts are also made of highly corrosion resistant non-metallic materials. The power transmission of drive and pump happens in a contactless way with firm NdFeB permanent magnets. So the pump is able to work without any mechanical shaft seals, which guarantees save supplies without any leakage of corrosive, toxic and explosive fluids. Pumps for potentially explosive ATEX Zones 1 or 2, are available in non-metallic materials also.

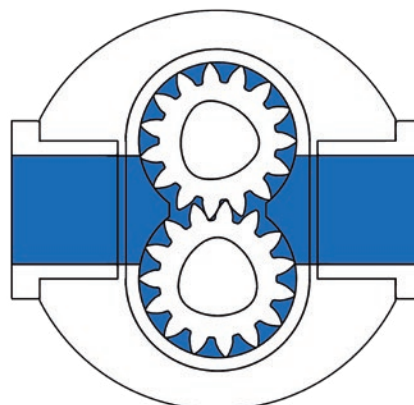

TEF-MAG Canada
Vissers Sales
(800) 367-4180

H [psi] H [bar]

600 1/min

900 1/min

1150 1/min

1450 1/min

1750 1/min

n [1/min]

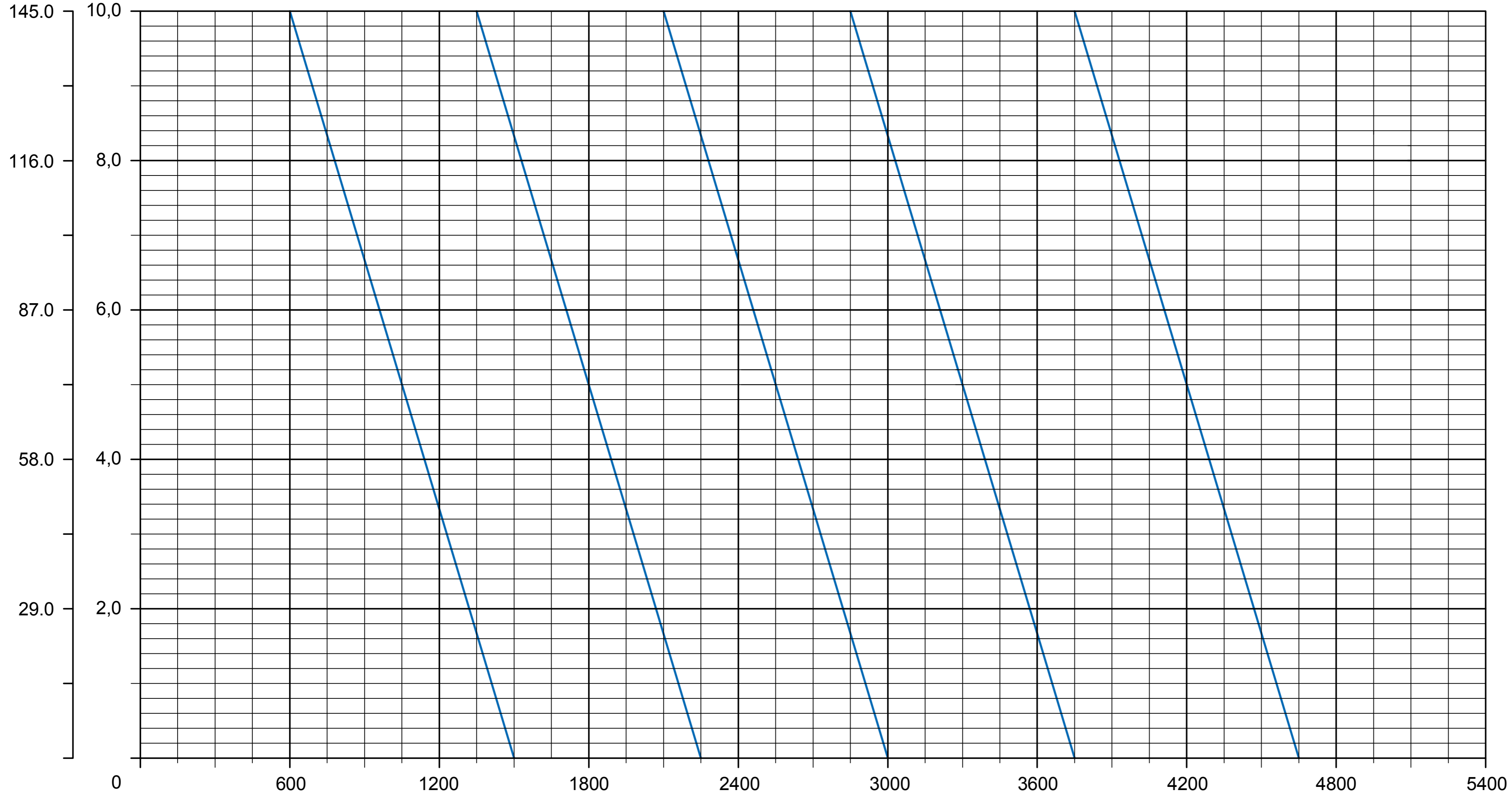

Q [l/h]

Q [U.S. GPM]



MARCH PUMPEN GmbH
 Rathenaustraße 2
 D-35394 Gießen
 www.march-pumpen.com
 info@march-pumpen.com

KENNLINIEN / PERFORMANCE CURVES			
Series	TEF-MAG		
Pump Size	TEF-MAG 3500		
Motor Power	1,1kW / 1.5HP	1,5kW / 2.0HP	2,2kW / 3.0HP
Speed	750 / 900 1/min	900 / 1150 1/min	1450 / 1750 1/min
Fluid Viscosity	1 mm ² /s	Fluid Density	1 kg/dm ³

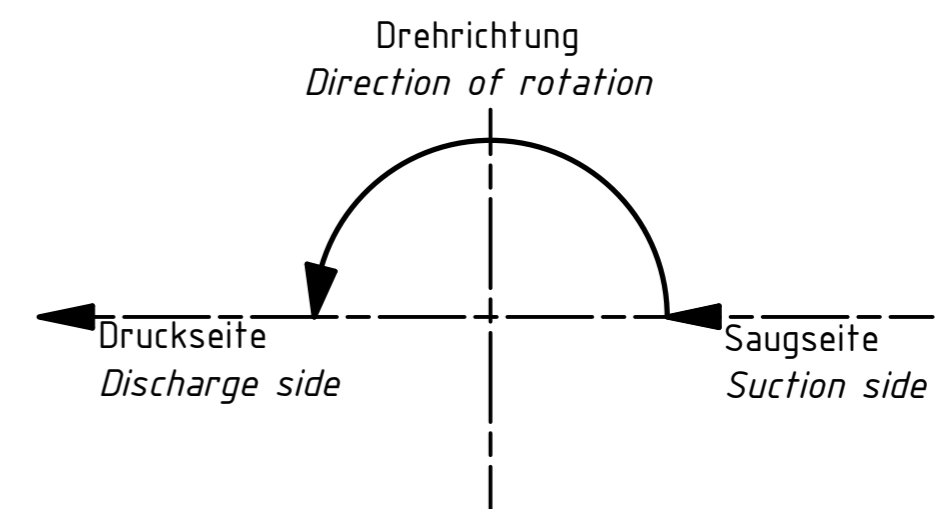
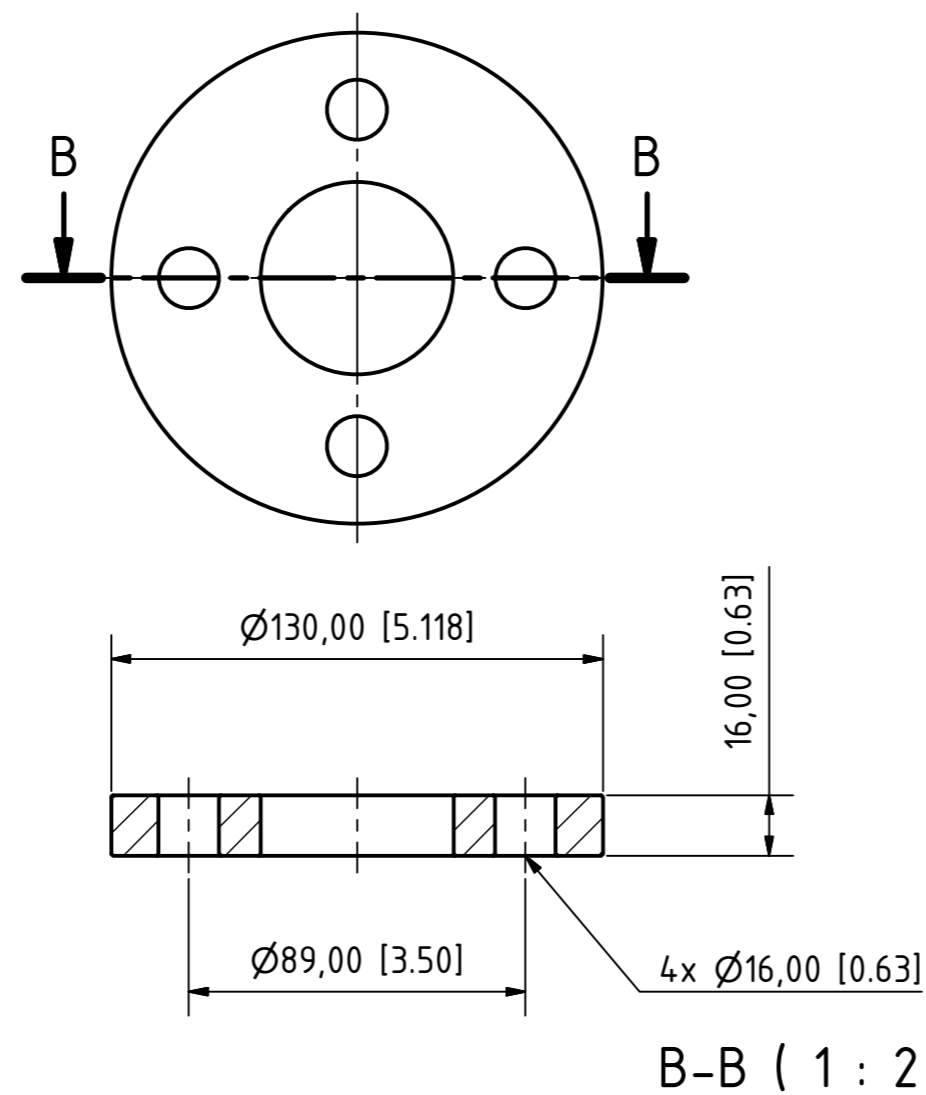
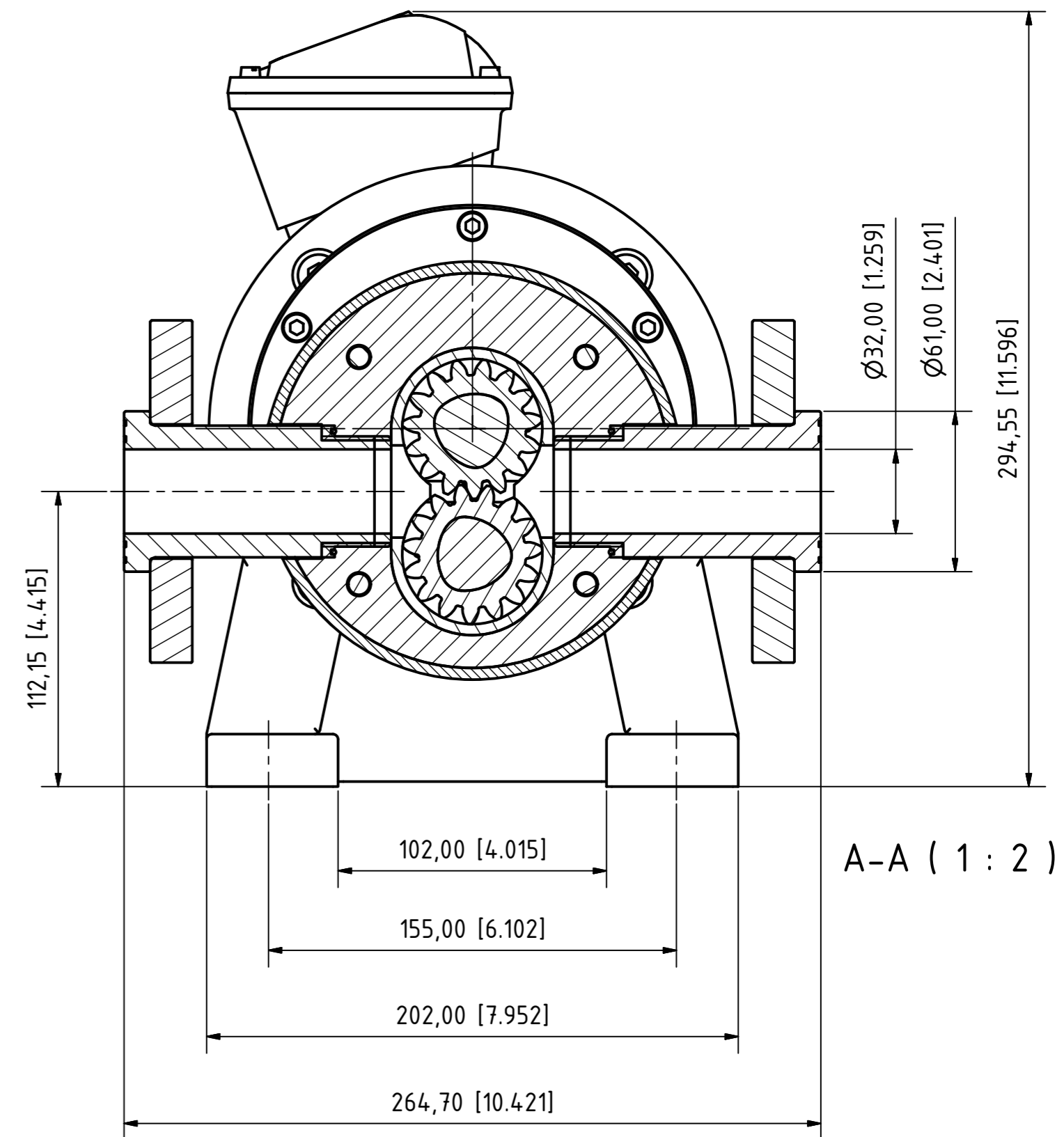
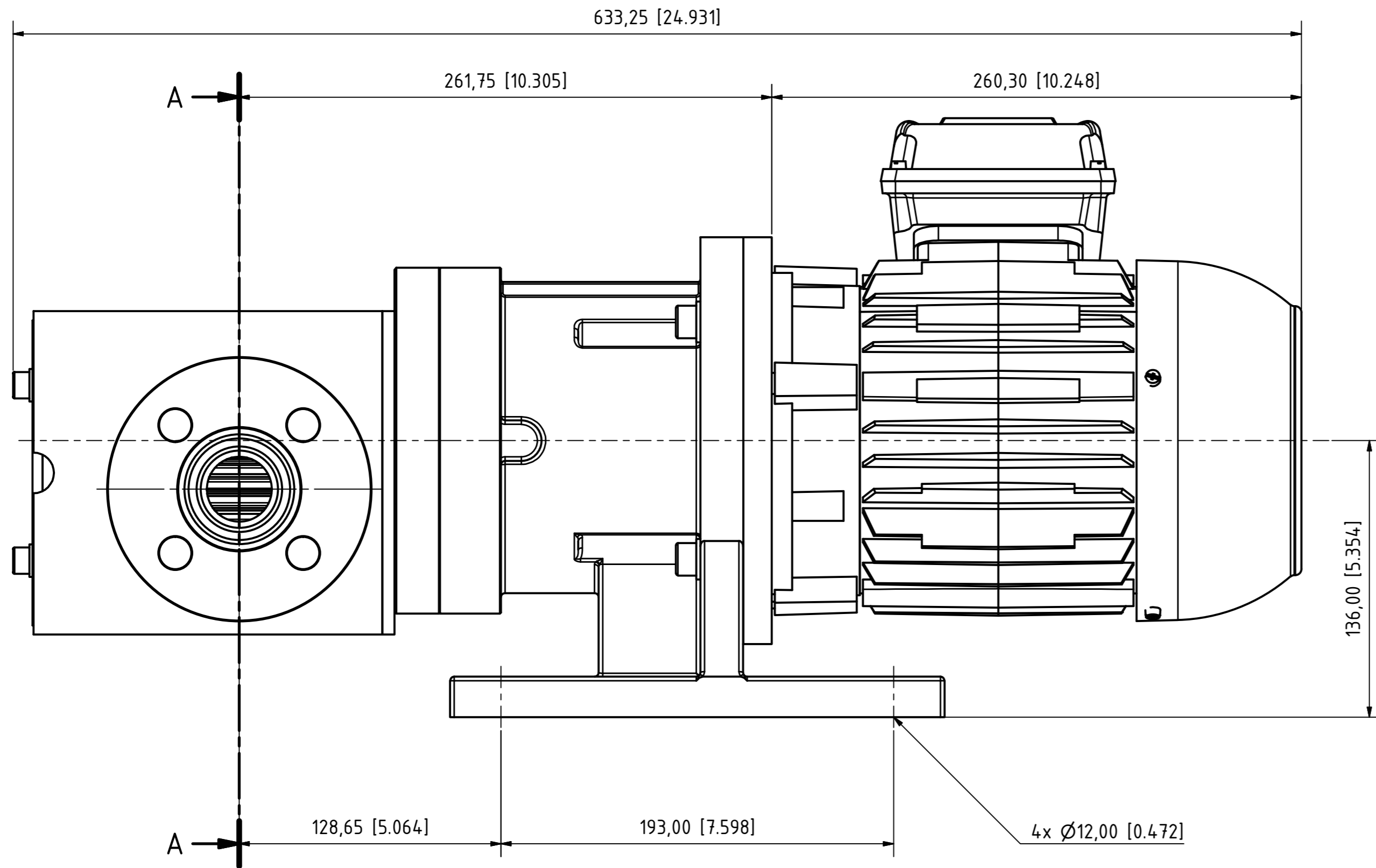

DIMENSIONS
mm [inch]

DRIVE
TEFC three phase asynchronous squirrel cage electric motor
Size: NEMA 143/145 TC
Manufacturer: WEG
Type: W22 NEMA
2.0HP, 1750 rpm, 60Hz

CONNECTIONS
Loose Flange ANSI 1 1/4" - 150lbs - PP-ST
or
1 1/4" BSP female thread
Suction and discharge side depends on direction of rotation.
Pump is reversible.

Alle Angaben unverbindlich, technische Änderungen vorbehalten! Technical data not binding and subject to change!
Copyright MARCH PUMPEN GmbH 2017

		MARCH PUMPEN GmbH & Co.KG Rätthausstraße 2 D-35394 Gießen info@march-pumpen.com www.march-pumpen.com		1:2	
		Datum	Name	DIMENSIONS TEF-MAG 3502 P-FA-H NEMA143/145TC STEEL COVERED TM-3502-P-FA_NEMA143/145TC_WEG	
		Gezeichnet	Lach		
		Kontrolliert			
		Norm			
Status	Änderungen	Datum	Name		