

Magnet drive gear pump-motor units MKCS08S/MKCS11S series



Find out more

The MK series pumps are designed to complete the existing MG series with improved performances in terms of flow rate, pressure, capability to handle high viscosity fluids and a wider offer of materials to suit most applications, from the food to the industrial and chemical markets. The housing of the pump and the internal metal parts are available in AISI 303, AISI 316L or SAF 2205. The rare earths driving magnet is capable to drive the pump at high pressure.

The quality of the materials of the assembled components allows handling of fluids with temperatures up to 120 °C (248 F).

The coupling with the MKCS08S-MKCS11S units designed for heavy duty, provides a reliable and noiseless operation in a compact size package. The pole-to-pole alignment of the two magnets provides the driving motion to the pump.

Decoupling will occur when the pumpload exceeds the maximum coupling torque provided by the alignment of the two magnets.

Available upon request:

- Ferrite driving magnet



MAIN APPLICATIONS

- Medical and surgical equipment
- Hemodialysis apparatus
- Laser apparatus
- Lubrication
- Ink-jet printing systems
- Cooling systems
- Laboratory instrumentation
- Water purification and ultra-filtration
- Sampling
- Food processing equipment

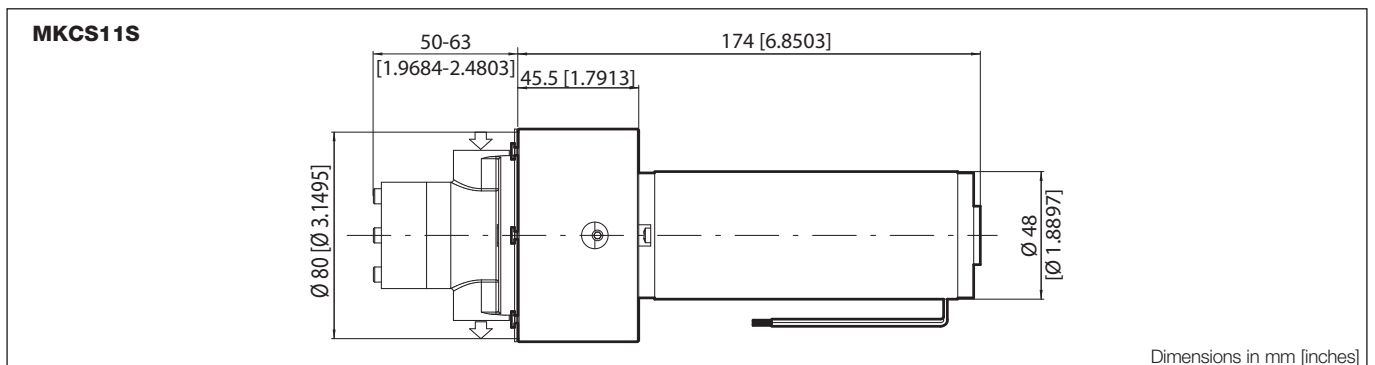
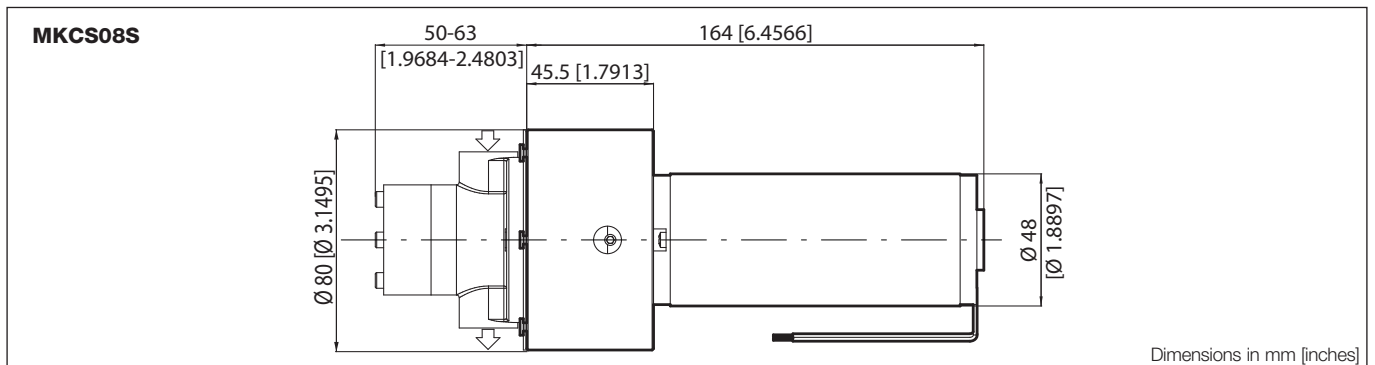

Magnet drive gear pump-motor units MKCS08S/MKCS11S series

POS	DESCRIPTION	FEATURES	CODE
A	Driving magnet	For 5 mm bore	MKAS05S
A+B	Complete adapter	For KAG M48x50 For KAG M48x60	MKBS48S
A+B+C	Complete motor assembly	See table below	MKCS08S MKCS11S

DRIVING UNIT	MKCS08S	MKCS11S
Voltage (V)	12 DC	24 DC
Rated speed (rpm)	3050	3150
Current consumption (A)	3.4	2.6
Output power (W)	32	49,5
Weight (Kg)	1.2	1.3

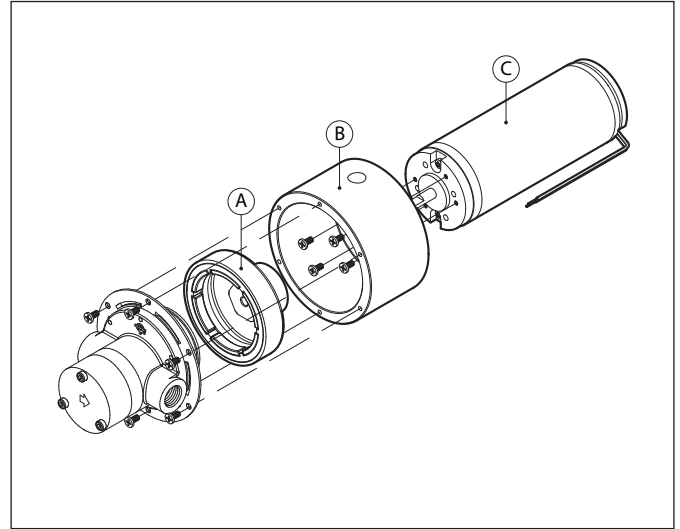

MKCS08S

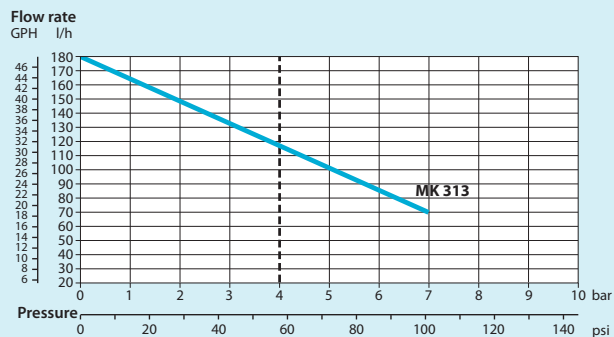
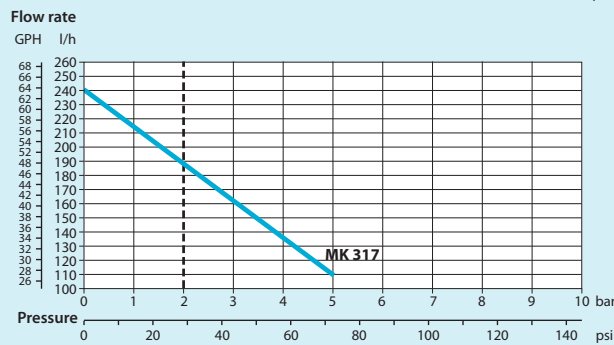
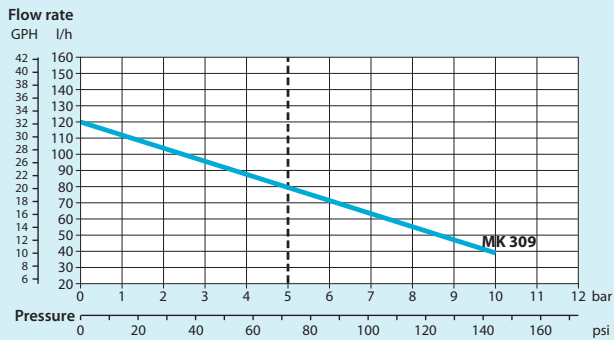

MKCS11S

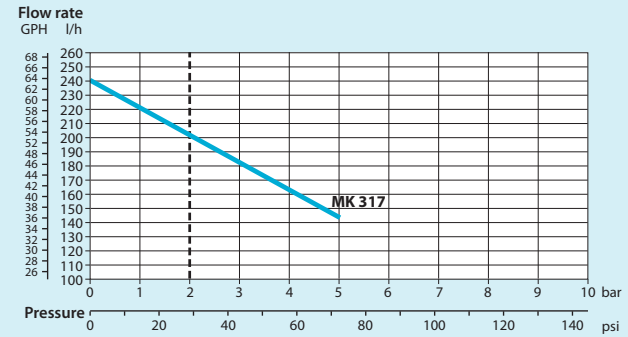
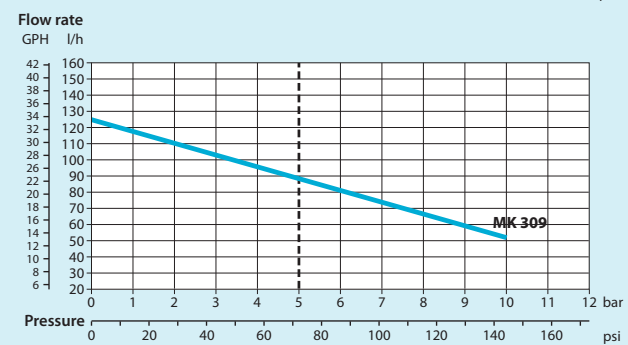
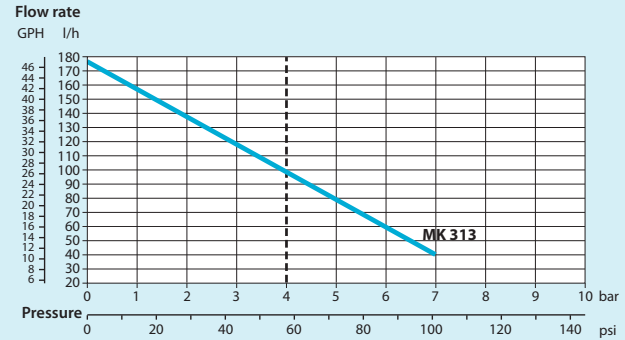

Note: Beyond the continuous duty (dotted) line a motor test is needed. Characteristics with water at 20 °C (68 F) and without relief valve, max vacuum 724 mmHg. Use filter before pump inlet not larger than 10 microns. Unit weight: 1.9 Kg (4.2 Lbs). Temperature requirements different from ambient temperature must be mentioned on the order.

Fluid-o-Tech reserves the right to alter the specifications indicated in this catalogue at any time and without prior notice.

Fluid-o-Tech srl
Via Leonardo da Vinci, 40
20094 Corsico, Milano, Italy
Tel. +39 02 9995 01
Fax +39 02 9995 0999
info@fluidotech.it

Fluid-o-Tech Int'l Inc.
161 Atwater St.,
06479 Plantsville CT (USA)
Tel. +1 (860) 276 9270
Fax +1 (860) 620 0193
info@fluid-o-tech.com

Fluid-o-Tech Int'l Inc. Japan
203, 2-17-19, Ebara, Shinagawa
Tokyo 142-0063, Japan
Tel. +81 (0) (3) 3783 9660
Fax +81 (0) (3) 3783 9661
k.kato@fluidotech.com

Fluid-o-Tech Asia (Beijing) Co., Ltd
Jingwei Industrial Zone,
Beifang Huairou, Beijing, 101400, PRC
Tel. +86 (0) (10) 6168 4650
Fax +86 (0) (10) 6168 4651
info@fluidotech-asia.com