

EchoPulse[®] LR30

Pulse Radar Level Transmitter



Application

The general purpose 26 GHz. pulse radar transmitter provides continuous level measurement up to 98.4' (30m) with a 4-20 mA signal output, and is configured via its remote push button display module. The non-contact liquid level sensor is intended for industrial wastewater, municipal storm or sewer lift station, reservoir, river, canal or open channel applications located below or above grade. Select this sensor for challenging process conditions that may include light surface foam or agitation, small trash or plant material, wind, condensation or vapor. Each comes with a 32.8' (10m) cable, mounting bracket and display module. The sensor is designed for bracket mount installation suspended above the liquid level.



Features

- Rugged IP68 sensor enclosure with 304 SS mounting bracket
- Simple configuration via remote push button display module
- 26 GHz. pulse radar is unaffected by sump process conditions
- Wall mounted display with windowed enclosure rated IP67
- 12" (30cm) dead band enables utilization of the entire sump
- LCD displays level in feet or meters with percent of span bar
- Optional display mode indicates the echo signal return curve
- Auto-temperature compensation for accurate measurement
- Self diagnostics with selectable fail-safe signal outputs
- Recognition, storage and rejection of false echo signal returns

Success

Industrial and municipal pump lift stations collect and transfer wastewater into treatment. These waste receptacles are very dynamic environments that may contain dirt, grease, oil, agitation, sludge, foam, condensation, chemicals or vapor. Here, a LR30 is mounted to the top side wall of a 16' sump. Its 26 GHz. pulse radar measurement is unaffected by the challenging process conditions.



EchoPulse® LR30

Pulse Radar Level Transmitter



Specifications

SENSOR

Range:	12" to 98.4' (30cm to 30m)
Frequency:	26 GHz.
Accuracy:	± 3mm
Dead band:	12" (30cm)
Beam angle:	12°
Supply voltage:	16-26 VDC
Max consumption:	22.5 mA
Signal output:	4-20 mA, two-wire
Signal invert:	4-20 mA, 20-4 mA
Signal fail-safe:	3.9 mA, 20.5 mA, 22 mA
Process temp.:	F: -40° to 212° C: -40° to 100°
Temp. comp.:	Automatic
Pressure:	Atmospheric
Enclosure rating:	IP68
Encl. material:	Nylon
Cable type:	6-conductor, shielded
Cable length:	32.8' (10m)
Cable jacket mat.:	PVC
Process mount:	304 SS bracket or 1" NPT

DISPLAY

Display type:	LCD, dot matrix
Display units:	Feet and meters
Display bar:	Percent of span
Display graph:	Echo signal curve
Configuration:	Push button
Enclosure type:	Wall mount
Enclosure rating:	IP67
Encl. material:	Polycarbonate
Conduit entrance:	(2) 1/2" NPT connectors

COMMON

Memory:	Non-volatile
Storage temp.:	F: -40° to 176° C: -40° to 80°
Classification:	General purpose
Certification:	cTUVus, FCC
Compliance:	CE, RoHS

Dimensions

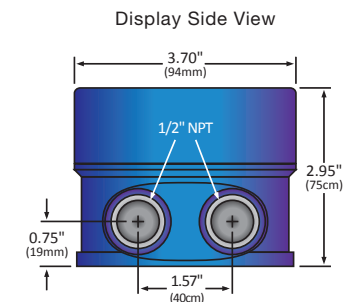
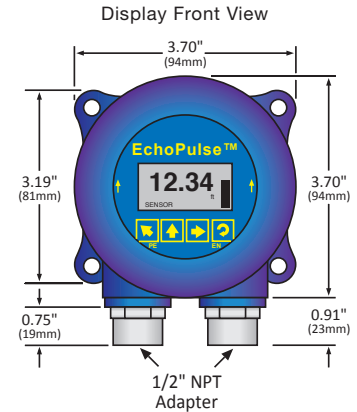
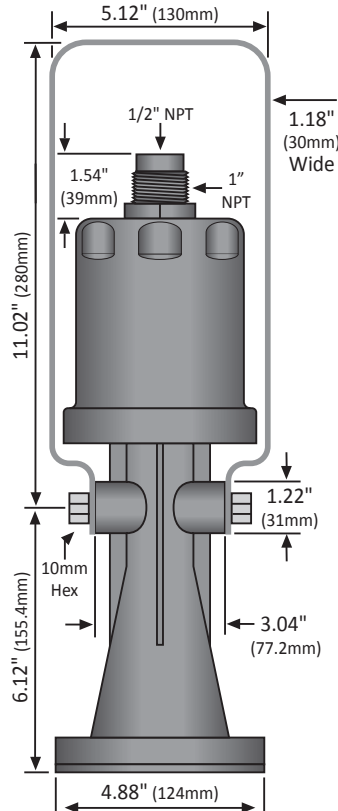

Ordering

LR30-0010-10 (1) (2)

NOTES

- 1) If you want help in selecting a sensor for your application, please go to our website and submit a Level Questionnaire. An engineer will review your requirements and suggest a product solution via email.
- 2) Includes the sensor, bracket, cable and display.

