

EXTREME PRESSURE. EXTREME PROTECTION.

SENTRY X P SERIES

HIGH PRESSURE STAINLESS STEEL PULSATION DAMPENERS

Another Innovation in Extreme Pulsation Dampening



Now Available with PTFE Bellows to 5,000 PSI

We combined our unique patented PTFE bellows design with our SENTRY XPA high pressure dampeners for your most extreme pumping applications. High pressure, highly aggressive fluid and high temperature? No problem. With excellent chemical and thermal resistance, our PTFE bellows have an excellent flex life, are compatible with virtually all chemicals and solvents, and can withstand temperatures up to 220°F (104°C). Now that's extreme...

- PTFE bellows models rated to 5,000 psi (345 bar)
- Elastomeric bladder models rated to 7,500 psi (517 bar)
- Corrosion resistant 316L Stainless Steel solid shell casing
- Positive seal threaded cap is low maintenance and easy to service
- ATEX models available

BLACOH[™]
FLUID CONTROL

Don't Pump Without Us.

XPA STAINLESS STEEL HIGH PRESSURE DAMPENERS WITH PTFE BELLOWS

12 cubic in (.20L)

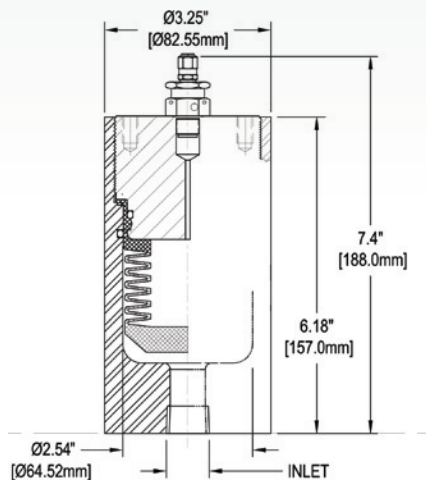

24 cubic in (.39L)

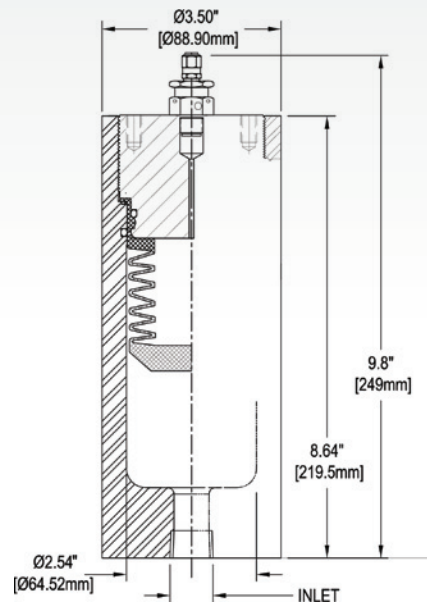

- PTFE bellows models rated to 5,000 psi (345 bar)
- 316L Stainless Steel shell casing
- ½" FNPT and BSP inlets; also available with ANSI Class Flange
- XPA models available in 8, 12 and 24 cubic inch to 7,500 psi (517 bar) with BUNA-N, EPDM and VITON bladders
- ATEX specific models conform to EU directives



Don't Pump Without Us.

Contact your local BLACOH distributor:

PULSATION DAMPENERS ■ SURGE SUPPRESSORS ■ INLET STABILIZERS ■ DIAPHRAGM SEALS/GAUGE GUARDS ■ BACK PRESSURE/PRESSURE RELIEF VALVES ■ LEAK CONTAINMENT/SPILL PREVENTION SYSTEMS

800.603.7867 | 951.342.3100 | www.BLACOH.com | Sales@Blacoh.com