



Model P/R60C-4 Differential pH or ORP Probes



Features

Differential Measurement

- Replaceable Salt Bridge
- Low Maintenance Cost
- Field-proven

Encapsulated Preamp

- Transmits up to 3000 ft.

Options

- 4-20 mA two-wire blind transmitter version available (model P/R65)
- ORP available with gold electrode

Description

The P60C-4 pH and the R60C-4 ORP probe are dependable industrial grade sensors designed to provide accurate measurement and longer service life under the most demanding conditions. Some features of these probes include: differential measurement technology, replaceable salt bridge and encapsulated preamp.

The P/R60C-4 incorporates all the benefits of differential measurement found in other models of the 60 series, field proven in thousands of installations. This technique uses two glass electrodes to make the measurement differentially with respect to a third metal electrode. The domed glass process electrode is specially designed for tough applications. The second electrode is immersed in a pH 7 buffer encapsulated in the probe.

This second electrode is protected from the process by a double junction replaceable salt bridge. The resulting

true differential measurement has several advantages over conventional probes: ground loop problems are virtually eliminated, and the salt bridge is easily replaced.

If the internal solution becomes contaminated, the probe can be rejuvenated at modest cost by replacing the salt bridge and reference solution. Automatic temperature compensation is accomplished through the use of a thermistor at the tip of the probe. This thermistor placement provides rapid response for process temperature variations.

The encapsulated preamplifier provides an output signal which can be transmitted 3000 feet over inexpensive cable. Another version encapsulates a blind 4-20 mA two wire transmitter which can transmit a virtually unlimited distance over a twisted pair cable. (See P/R65 data sheet).

Applications

- Process Control
- Industrial and Municipal Water Treatment
- Industrial and Municipal Waste Treatment and Neutralization
- Fume Scrubbers
- Suitable for the Plating, Circuit Board Manufacturing, Food and Beverage, Chemical Processing, Pulp & Paper, Mining, Nuclear Energy and Pharmaceutical Industries

Model P/R0C-4 Differential pH or ORP Probes

Technical Data

Measuring Range

pH 0 to 14.00 pH
(Consult factory for applications below 2 and above 12)

ORP -2000 mV to 2000 mV

Flow Rate 10 ft./sec maximum (3 metres/sec)
Flow should be as low as possible in low conductivity water and in solutions with high suspended solids

Wetted Materials CPVC, kynar, glass, titanium palladium alloy and EPDM (platinum for ORP probe)

Transmission

Distance 3000 ft. (900 m)

Sensitivity

pH 0.001 pH

ORP 0.1 mV

Stability

pH 0.03 pH per day, non-cumulative

ORP 2 mV per day, non-cumulative

Temperature Compensation

Automatic -5 to 95°C (23 to 203°F)

Pressure Limit 100 psig at 65°C maximum

Temperature Limits

CPVC -5 to 95°C (23 to 203°F)

The temperature limit of probes in flow-through applications is limited by pressure and by the pipe fitting material.

Probe cable 5 Conductor plus shield, 15 ft. (4.6m) long

Related Products

CABLES & ACCESSORIES

JB-1 NEMA 4X junction box
C42-5PXXX Interconnect cable; specify length
C35-17K Salt bridge kit w/ kynar outer junction (Package of 3)
C35-17 Salt bridge kit w/ ceramic outer junction (Package of 3)

CALIBRATION SOLUTIONS

A35-13 pH 4 Buffer, 500mL.
A35-14 pH 7 Buffer, 500mL.
A35-24 pH 10 Buffer, 500mL.
A35-40 ORP Buffer, 200mV, 500mL
A35-41 ORP Buffer, 600mV, 500mL

Ordering Information

P60C-4 pH probe, 1 1/2" NPT threaded body
P60C-4-H pH probe with Hard glass electrode
P60C-4-A pH probe with Antimony electrode
R60C-4 ORP probe, 1 1/2" NPT threaded body
R60C-4-H ORP probe with Hard glass electrode
R60C-4-G ORP probe with Gold electrode

Dimensions

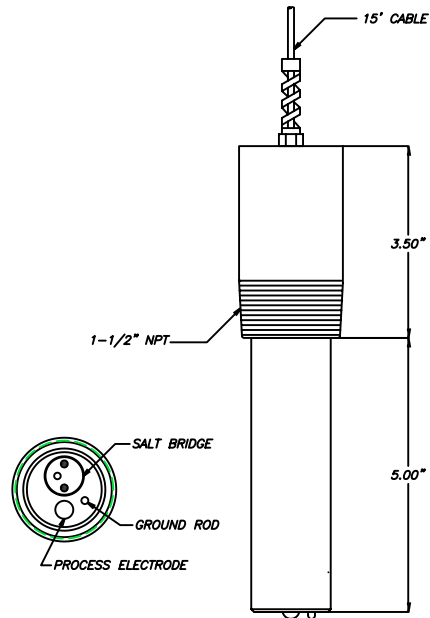

Differential Measuring Technique

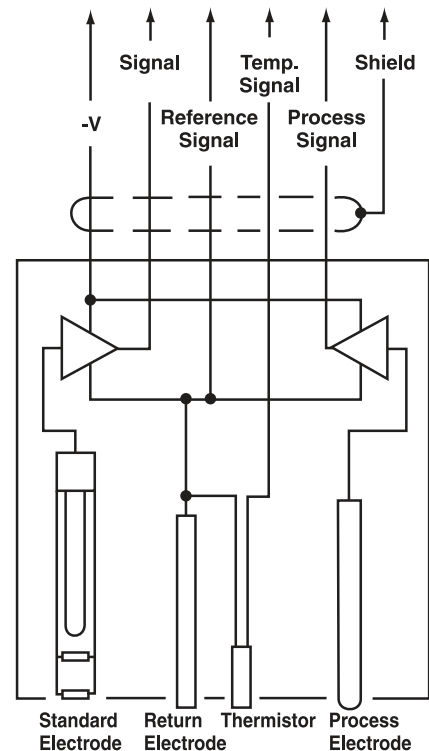

DIFFERENTIAL pH MEASUREMENT



AquaMetrix Inc.
www.aquametrix.com
1-800-742-1413

