

PLAN VIEW

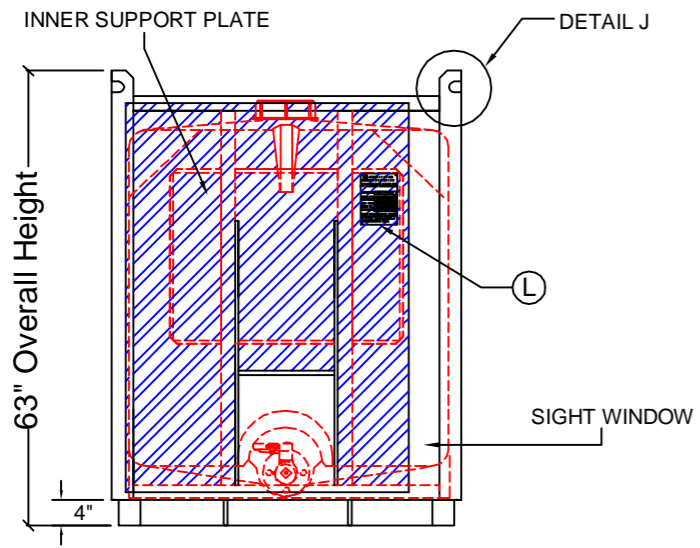

FRONT VIEW

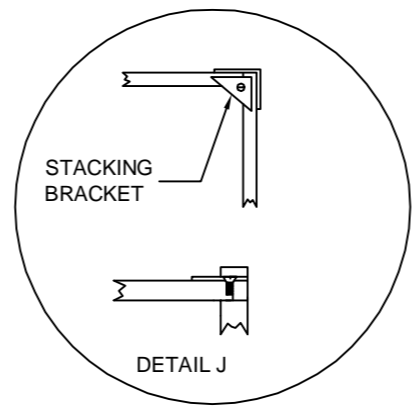
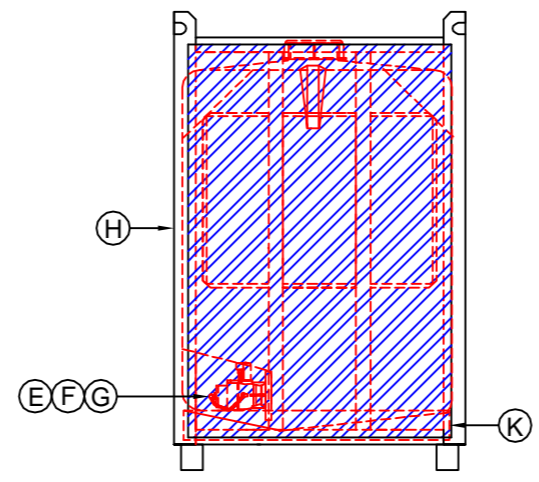

SIDE VIEW

MATERIALS LIST

ITEM	SIZE	DESCRIPTION	NOTES
A		250 IG (1130 L) POLYETHYLENE BOTTLE	
B	6"	ORANGE HDPE THREADED LID W/ TIE-DOWN	
C		LID GASKET	EPDM OR VITON
D		VENT - VACUUM & PRESSURE RELIEF (OPTIONAL)	IN LID
E	2"	FLANGE GASKET	EPDM OR VITON
F	2"	BALL VALVE; POLYPROPYLENE OR 316-SS	FNPT OR CAMLOC
G		VALVE MOUNTING HARDWARE KIT	
H		FULLY ENCLOSED STEEL FRAME AND VALVE PROTECTION GATE	
J		FRAME CORNER STACKING BRACKET W/ SCREW	4 PCS REQUIRED
K		BLACK POLY FRAME PILLOW	
L		ALUMINUM U.N. FRAME TAG	

- TECHNICAL DATA:
 1. CAPACITY: 250 IMP GAL, 1130 L
 2. WEIGHT: 726 LBS, 329 KG (APPROX) EMPTY
 3. PRIMARY MARKINS: U.N. 31HA1/Y/

REV	DATE	DESCRIPTION	BY	APPD	REVD	
REVISIONS						
CUSTOMER						
TITLE		ACO JOB NO:				
		PURCHASE ORDER NO:				
		PURCHASER'S EQUIP. NO:				
THIS DRAWING IS THE PROPERTY OF ACO CONTAINER SYSTEMS LTD. AND SHALL NOT BE COPIED OR TRANSFERRED WITHOUT THE WRITTEN CONSENT OF ACO CONTAINER SYSTEMS LTD.						
ENGINEERS SEAL		ACO CONTAINER SYSTEMS LTD.				
PICKERING - ONTARIO - CANADA						
ACO CONTAINER SYSTEMS LTD. 794 MCKAY RD. PICKERING, ONTARIO, CANADA L1W 2Y4 TEL. 905-683-8222 FAX 905-683-2969		DESIGNED	S.A.			
		DRAWN	D.G.			
		CHECKED				
		APPROVED				
		SCALE	N.T.S.			
DWG No	PTC-250-FE				REV	0
		DATE	04-16-07			