

Yellow Series
General Purpose
Nylon Body

Pass .71" / 18mm Solids

Patented Lubrication
& Stall Free Air Motor

Patented Long Life
Diaphragm Design

Self-Cleaning Ball
Valve Enclosure



Red Series
FRASplas Body-
Fire Retardant
Antistatic
Construction -
Safe for Explosive
Environments
Atex M1 Rating



Ebony Series
Noryl Body-
Corrosive
Resistant
Internals- For
Acids And Other
Hazardous
Liquids.

Features / Benefits

- Patented long life diaphragm & self-cleaning valve
- Low air consumption
- True lube-free & stall-free air motor: less sensitive to abrasive particles in the air supply and no oil emissions in the exhaust air
- Low weight due to light weight plastic & aeronautical design approach. No need for metal pumps
- Anti-icing: not affected by moisture in air line
- Large solids handling
- High suction lift
- Longer lasting air motor due to unique design and modular components that eliminate the need to replace the entire motor when worn.
- Conductive plastic (FRASplas) pumps are safe for explosive environments. Rated and certified to ATEX M1
- Low noise level

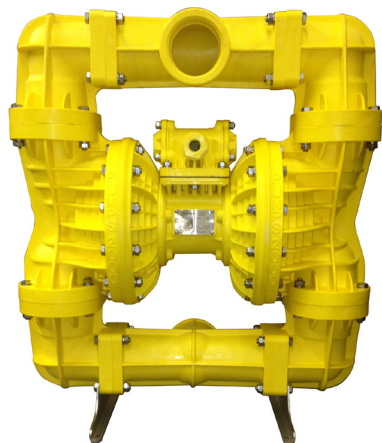

Ball Valve

"Pumps 2000" air operated dual diaphragm pumps were specifically designed for harsh mining duties and are guaranteed to outperform and outlast the competition due to a number of patented design features. The light weight feature provides ease of mobility and reduces the risk of injury. Low air consumption and long lasting lubrication free parts means low cost running and reduced maintenance. Suitable for pumping applications in all industries.

Performance Curve

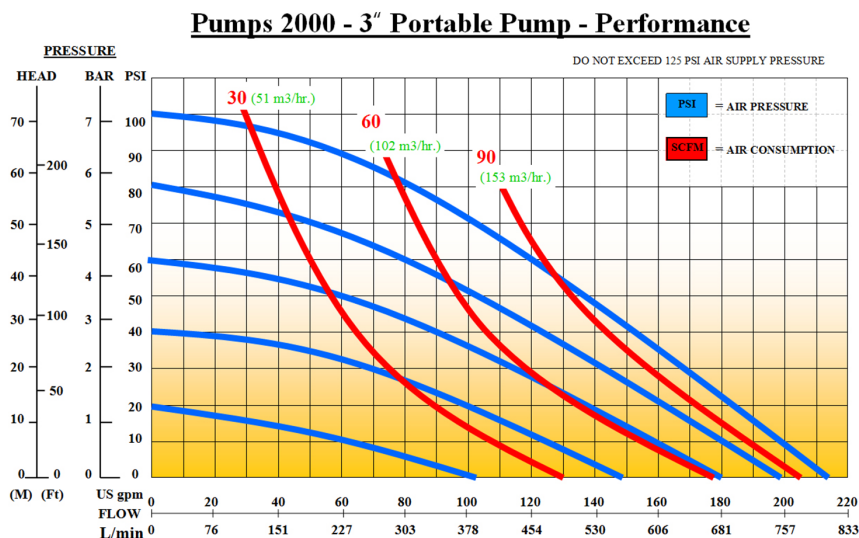

AIR PRESSURE:	Tested at 100 psi (Not to exceed 125 psi)
FLOW RATE:	0 – 215 gpm / 814 lpm
FLUID CONNECTION:	3" (Internal Thread)
AIR INLET PORT:	1/2" (Internal Thread)
EXHAUST PORT:	3/4" (Internal Thread)
DELIVERY PRESSURE:	Tested to 87 psi
SUCTION PRESSURE:	Tested to 19' / 5.8m dry and 31' / 9.5m wet
PARTICLE SIZE:	.71" / 18mm Spherical
PUMP WEIGHT:	From 62 lbs / 28kg

Available from:



www.pumps2000america.com

